

## Models

A75 A100 A130

## Features

- No contact between operating components in the casing
- Flat power curve over entire vacuum range prevents motor overload
- Reduced stress on motor shaft and bearings
- Increased water handling capability prevents heat build-up, extends life of mechanical seals
- Compact, close-coupled design eliminates need for inter-stage manifold or motor alignment
- Shrouded rotor increases pumping efficiency for high vacuum and low water consumption
- Fast delivery on standard materials and local support



## Materials of Construction

### Casing, Cover, Rotor, Port Cylinder:

- All Bronze
- Cast Iron, Bronze Fitted
- All Stainless Steel

### Mechanical Seals:

- BUNA — Optional
- Viton™ — Cast Iron Bronze Fitted, All Bronze, Stainless Steel
- EPR — Optional
- Kalrez™ — Optional

### Drive Options:

- Pedestal Frame
- Close-coupled motor

### Stocked Motors:

- TEFC – 3Ø
- TEFC – 1Ø

### Optional Motors:

- XP Class I, GpD – 3Ø — Optional
- XP Class I, GpD – 1Ø — Optional

## Typical Pumping Speed Curves

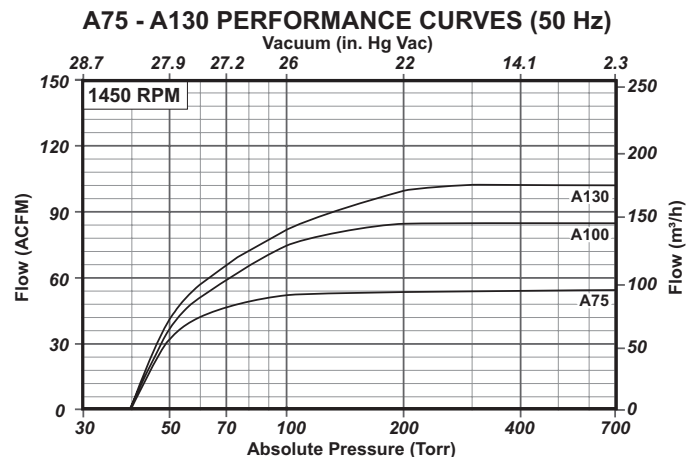
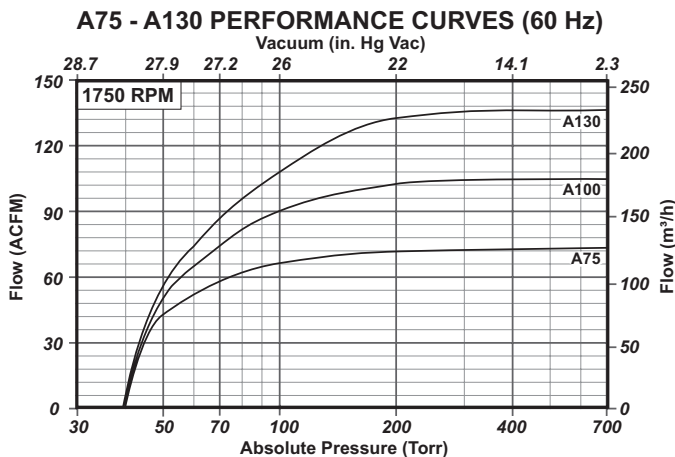

## Dimensions

Values shown are approximate and should not be used for construction.  
 Certified drawings are available through your local Tuthill Vacuum & Blower Systems Sales Professional.

### Close-coupled Design

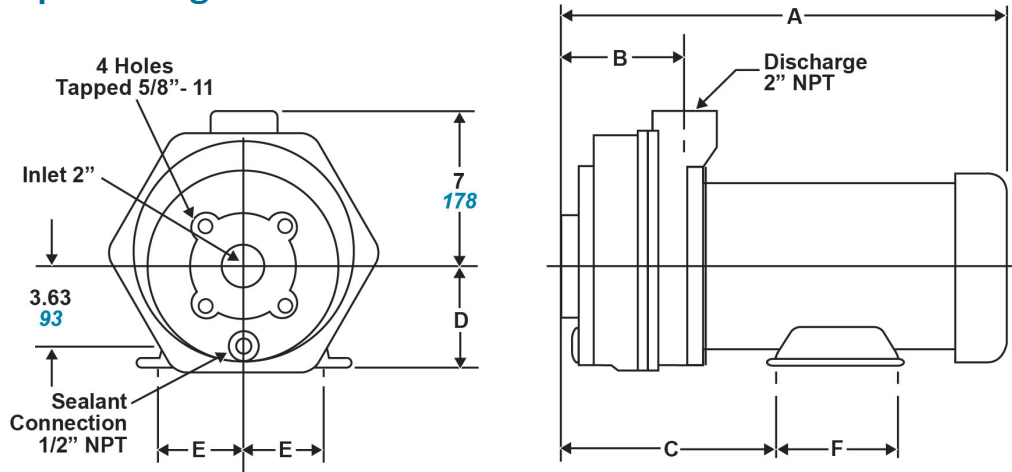

MODEL	FRAME	INLET	inches/mm						MOTOR HP	Weight (lbs./kg)
			A	B	C	D	E	F		
A75	184TCZ	2" Flange	20.2 / 513	5.8 / 147	10 / 254	4.50 / 114	3.75 / 95	5.5 / 140	5	180 / 82
A100	213TCZ	2" Flange	23.1 / 587	7.1 / 180	12.1 / 307	5.25 / 133	4.25 / 108	7.0 / 178	7 1/2	195 / 89
A130	215TCZ	2" Flange	25.3 / 642	8.1 / 206	13.1 / 333	5.25 / 133	4.25 / 108	7.0 / 178	10	250 / 114

### Pedestal Mount Design

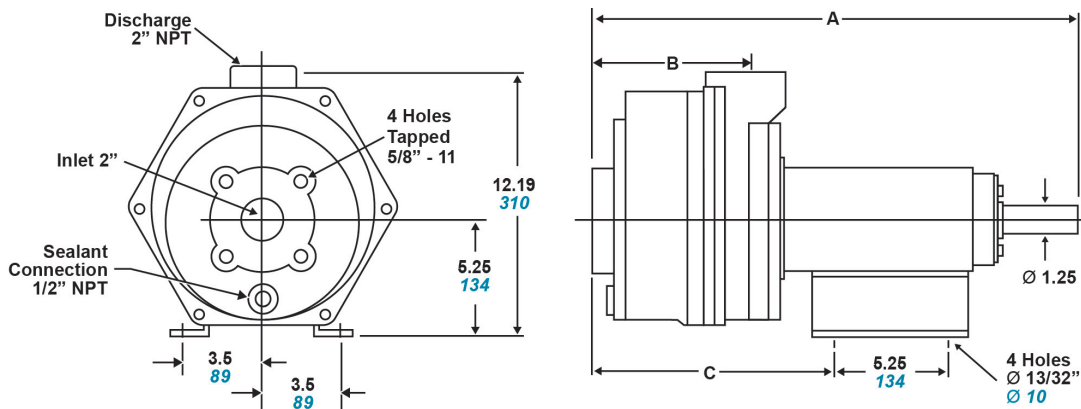

MODEL	INLET	inches/mm			Weight (lbs./kg)
		A	B	C	
A75	2" Flange	20.57 / 369	5.75 / 89	9.44 / 157	125 / 57
A100	2" Flange	21.88 / 377	7.07 / 97	10.75 / 165	130 / 59
A130	2" Flange	22.88 / 396	8.07 / 117	11.75 / 185	145 / 66

Your Local Tuthill Vacuum Blower Systems Sales Professional:

#### PSI Prolew Inc.

975 Selkirk, Pointe-Claire  
 Québec, Canada H9R 4S4  
 Tel: (514) 697-7867  
 Fax: (514) 697-0057  
 www.psiprolew.com



#### PSI Prolew Inc.

3770A Laird Road, Unit 1,  
 Mississauga, ON L5L 0A7  
 Tel: (905) 820-6330  
 Fax: (905) 820-6338  
 www.psiprolew.com



#### Tuthill Vacuum & Blower Systems

4840 West Kearney Street  
 Springfield, Missouri USA 65803-8702  
 o 417.865.8715 800.825.6937 f 417.865.2950  
 tuthillvacuumblower.com

