

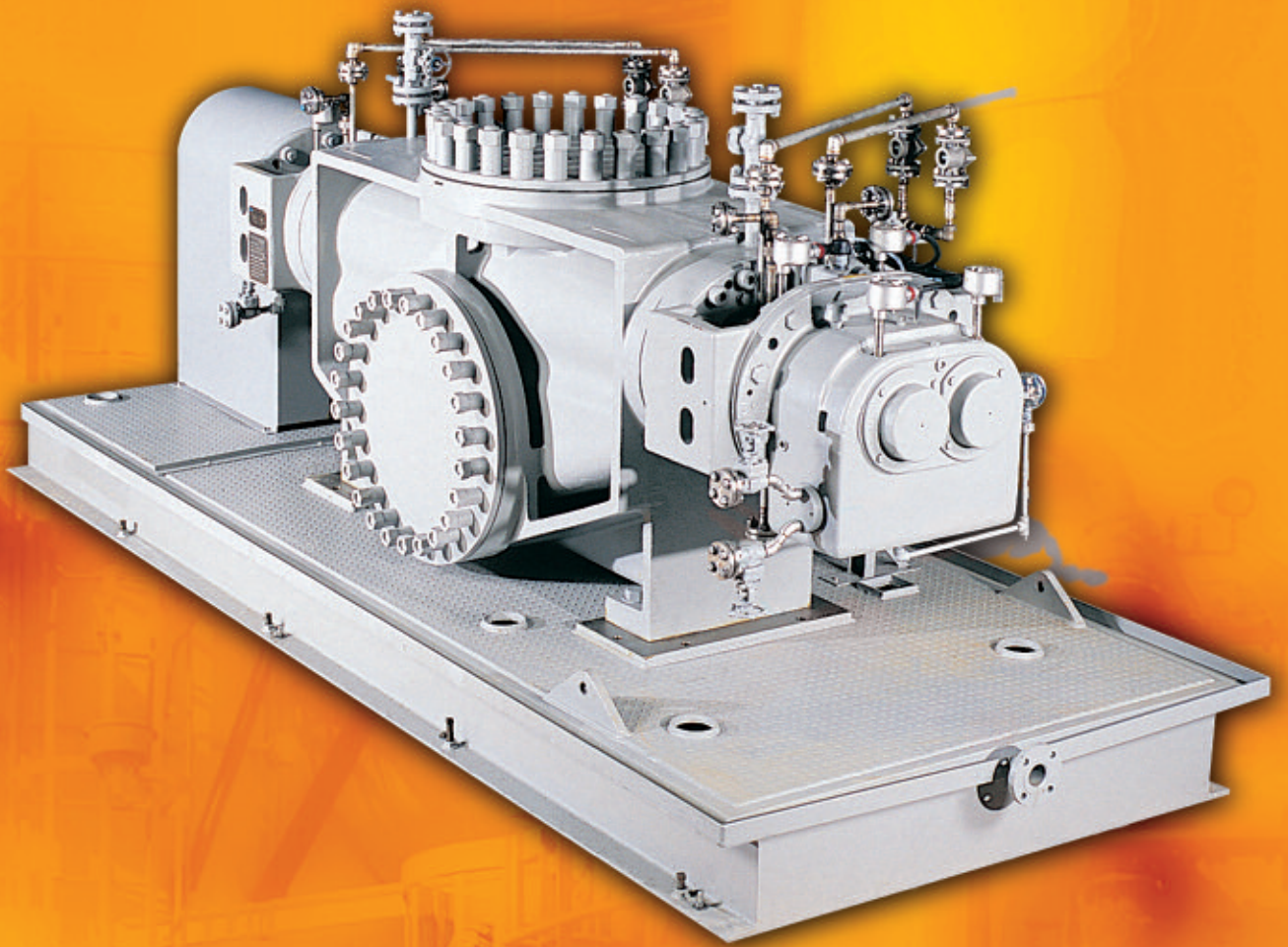

# *TSP*

## *Double-Suction, Twin-Screw Pump*



*Experience In Motion*

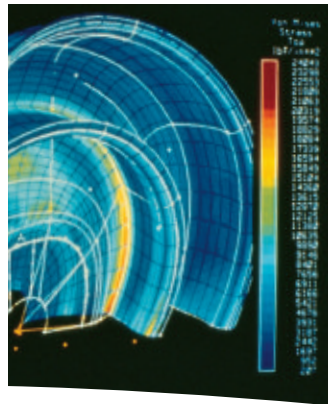

## ***Pump Supplier To The World***

*Flowserve is the driving force in the global industrial pump marketplace. No other pump company in the world has the depth or breadth of expertise in the successful application of pre-engineered, engineered and special purpose pumps and systems.*

### ***Pumping Solutions***

Flowserve is providing pumping solutions which permit customers to continuously improve productivity, profitability and pumping system reliability.

### ***Market Focused Customer Support***

Product and industry specialists develop effective proposals and solutions directed toward market and customer preferences. They offer technical advice and assistance throughout each stage of the product life cycle, beginning with the inquiry.



### ***Dynamic Technologies***

Flowserve is without peer in the development and application of pump technology, including:

- Hydraulic engineering
- Mechanical design
- Materials science
- Intelligent pumping
- Manufacturing technology

### ***Broad Product Lines***

Flowserve offers a wide range of complementary pump types, from pre-engineered process pumps, to highly engineered and special purpose pumps and systems. Pumps are built to recognized global standards and customer specifications.

Pump designs include:

- Single stage process
- Between bearing single stage
- Between bearing multistage
- Vertical
- Submersible motor
- Rotary
- Reciprocating
- Nuclear
- Specialty

**TSP  
Twin-Screw  
Pump**

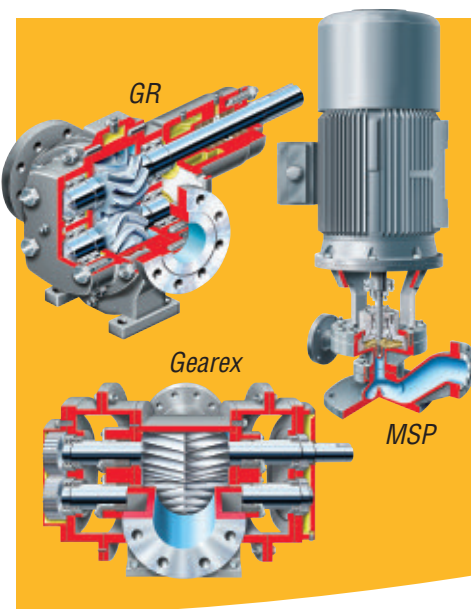

**Versatile and Reliable**

*The Flowserve TSP double-suction, twin-screw rotary pump is the most versatile of all viscous liquid pumps. Built upon the proven heritage of the Sier-Bath twin-screw positive displacement pump, the TSP continues to provide the same pulse free flow, high suction lift and self priming capabilities of its predecessor, now incorporating field proven design enhancements to further improve reliability and ease of maintenance. These advanced features, coupled with the wide application coverage of this product clearly demonstrate the versatility of the Flowserve TSP.*

**Advantages Over Gear Pumps**

- Lower NPSH requirements
- Higher differential pressure capability
- Lower shear stress
- Greater solids capability
- Lower operating noise levels

**Applications**

- Crude oil transfer
- Fuel oil burner feed
- Cargo loading and unloading
- General petroleum
- Chemical dosing
- Lube oil transfer and feed
- High viscosity polymers
- Reactor re-circulation
- Greases and fats
- Pulp and paper
- Slurries

**Benefits of the TSP**

- Ease of Maintenance
  - Back pull-out design of rotating assembly
  - Split bearing bracket construction
  - Cartridge type mechanical seals
  - Tapered shaft mounting of coupling hub
  - No special tools required
- Versatility
  - High volumetric efficiency over a wide range of viscosities
  - Run-dry capability
  - High temperature operation
  - Accommodates multiple seal types
- Heavy-Duty Reliability
  - Robust, one-piece cast casing design
  - Oversized and rigid integral shaft design
  - Oversized bearings
  - Abrasion-resistant coatings
- Low Total Cost of Ownership
  - Individual serviceability of bearings and mechanical seals
  - Refurbishing program for shafts and casings
  - Replaceable rotating assembly

**Complementary Pump Designs**

Flowserve also offers these pump designs:

- GR double helical, non-timed internal bearing gear pump
- Gearex double helical, timed external bearing gear pump
- MSP vertical in-line, medium speed pump

**TSP**  
**Twin-Screw**  
**Pump**

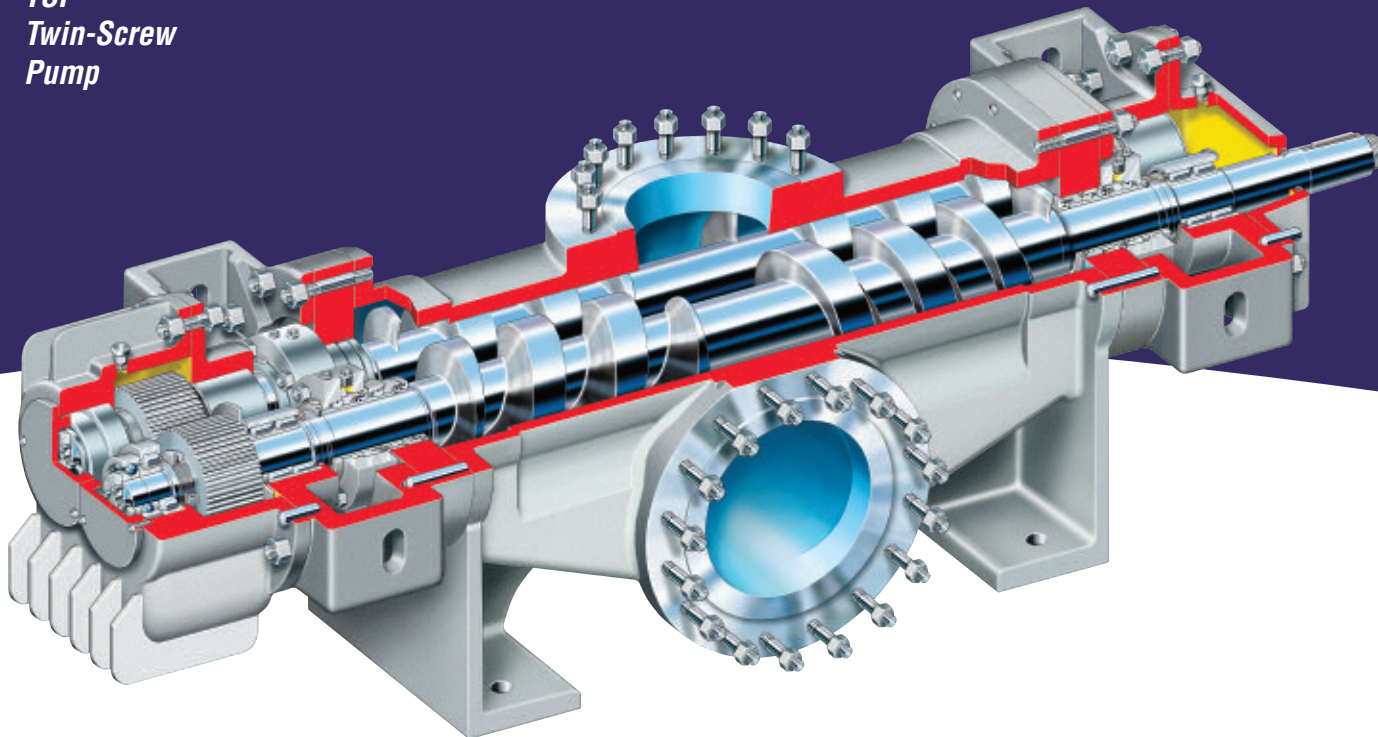

*The Flowserve TSP features a double-suction, timed twin-screw pump design built in accordance with API 676, latest edition. It improves upon traditional rotary pump designs by providing smoother, more constant flow across a wide range of viscosities, temperatures and pressures.*

The bearings and timing gears are located in separate oil reservoirs to ensure long pump life and high reliability. This design is suitable to handle fluids that are contaminated or have poor lubricity. It is also preferred for high temperature and high viscosity services or where run-dry capability is an operational requirement.

**Operating Parameters**

- Flows to 2550 m<sup>3</sup>/h (11 200 gpm)
- Pressure to 100 bar (1450 psi)
- Temperatures to 450°C (850°F)
- Viscosities to 200 million SSU
- Slurry concentrations to 70% by weight
- Shaft tip speeds to 30 m/s (100 ft/s)

**Double Suction Design** contributes to low NPSHR and balanced hydraulic loads. Robust cast casing has very low inlet losses and ensures mechanical seals are exposed only to pump inlet pressure

**External Bearings and Timing Gears** are located in separate oil reservoirs, thereby eliminating exposure to the pumped fluid. This design provides ideal lubrication for these critical components

**Oversized, Integral Shaft Design** results in low operating shaft deflections and high torque handling capability

**Versatile API 682 Seal Chamber** readily accommodates multiple seal types without field modifications and meets HSE regulations

**Split Bearing Bracket Construction** provides easy access to bearings and mechanical seals to facilitate maintenance

**AGMA 11 Precision Ground Timing Gears** transmit power from the pump drive shaft to the driven shaft and maintain rotational clearances between the screws. Metal-to-metal contact is eliminated thereby reducing wear

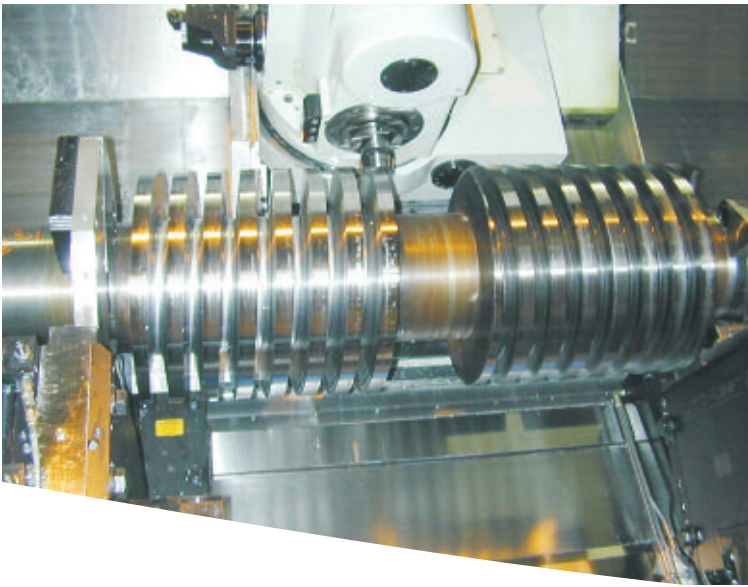

**Customized Screw Pitch**

Design capacity and required pressure are achieved by varying the screw pitch in 3 mm (1/8 in) increments, thereby achieving the optimum hydraulic and mechanical efficiencies. Pumps can then be coupled to standard synchronous speed drivers reducing original equipment costs. Utilizing state-of-the-art manufacturing methods precise tolerances can be consistently achieved.

**Flowserve Multiphase Twin-Screw Pump Thrust Bearing Design**

The TSP incorporates this field proven feature from the Flowserve multiphase twin-screw pump design. This innovative design provides a robust outboard bearing support for the between bearings mounted timing gears, ensuring optimum timing gear alignment and mesh resulting in low operating vibration levels. This well engineered bearing design provides for a simple and controlled method for bearing installation that can be carried out in the field.

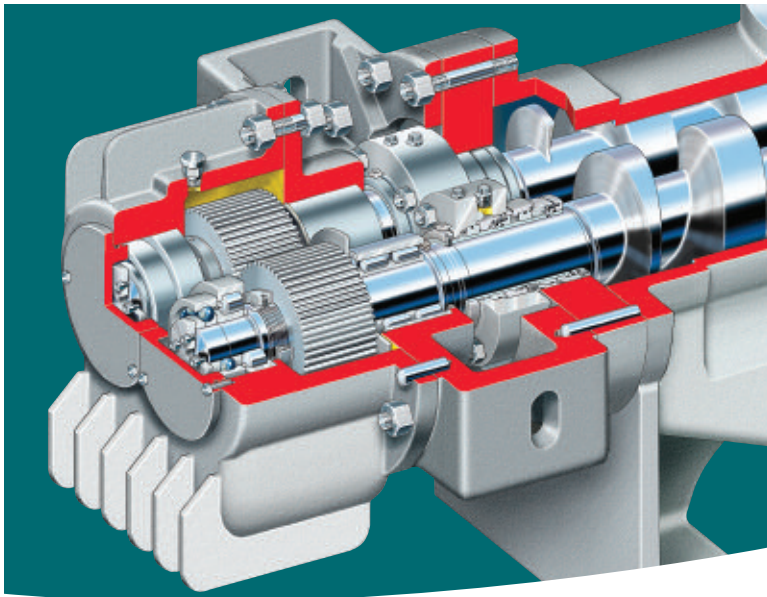

**Split Bearing Bracket Construction**

A strong maintenance feature of the TSP is the split bearing bracket design. The bearing housing portion of the bracket can be separately removed to permit servicing of the bearings without disturbing the mechanical seals. Since the parting flange of the bracket is near the TSP casing maximum access is provided to the mechanical seals, which similarly can be individually removed and replaced without disturbing the seal on the adjacent shaft. The critical positioning of the bearing bracket assembly is maintained using hardened dowel pins so proper reassembly is assured.

**Tapered Coupling Extension**

The TSP's tapered coupling extension eliminates the maintenance challenge of removing interference-fit mounted coupling hubs, especially at remote field locations. As a result, pump downtime is significantly decreased and the potential for damaging the pump drive shaft and/or coupling hub is eliminated.

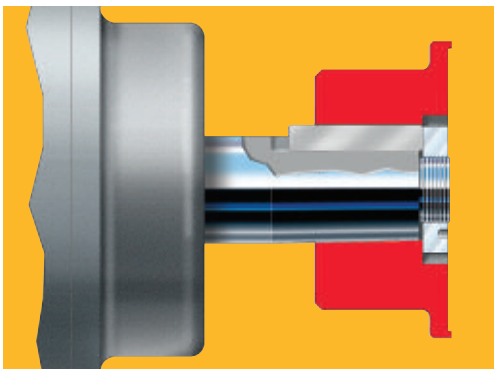
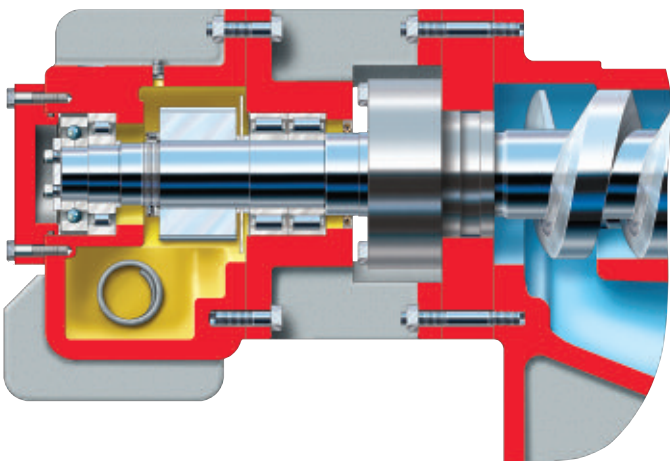

**Options and Technical Data**

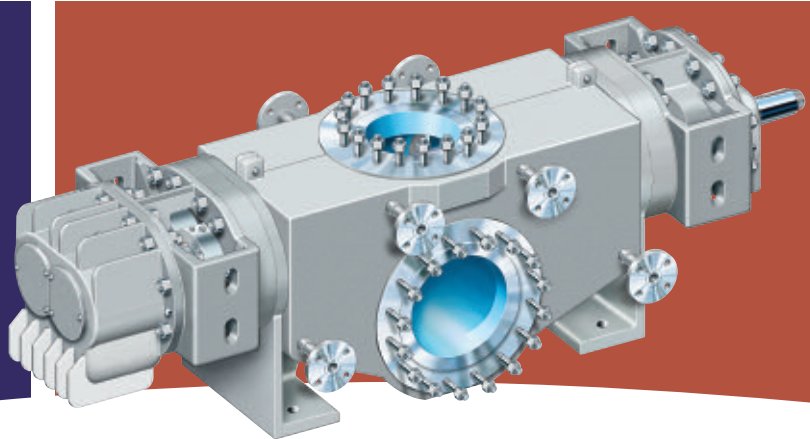

**Pre-Engineered High Temperature Option**

- High pressure, high temperature bolt-on hot oil or steam jacket for heat tracing of pumping chambers
- High temperature bellows mechanical seals in both single and double cartridge configurations
- Internal design clearances engineered to accommodate thermal expansion of pump while still achieving the rated conditions of service
- Cooling coils fitted in drive and non drive end bearings houses to support pump operation up to 450°C (850°F)
- Fitted with high temperature gaskets and elastomers

**Hard, Abrasion-Resistant Coatings**

Hard coatings reduce corrosion and wear on critical parts in challenging services. Hard coatings also offer the additional benefit of protection against galling in the event of short-term upset conditions. The result is increased mean time between pump repair.

- Casing bores can be coated with overlays with a minimum hardness of 70 Rc
- Screw outer diameters can be manufactured with abrasion-resistant coatings with a minimum hardness of 40 Rc
- In-house testing lab to confirm pressure and velocity load handling characteristics of coatings

**Materials of Construction**

Component	Standard Design	API Design	Corrosion-Resistant Design
Casing	Ductile iron	Cast steel	Stainless steel
Integral shafts	Carbon steel	Carbon steel	Stainless steel
Seal plate half of bracket	Carbon steel plate		Stainless steel
Bearing housing half of bracket	Cast steel		
Front cover; Gear housing	Cast steel		
Rear caps	Carbon steel		
Timing gears	Case carburized carbon steel		

**TSP Range Chart**

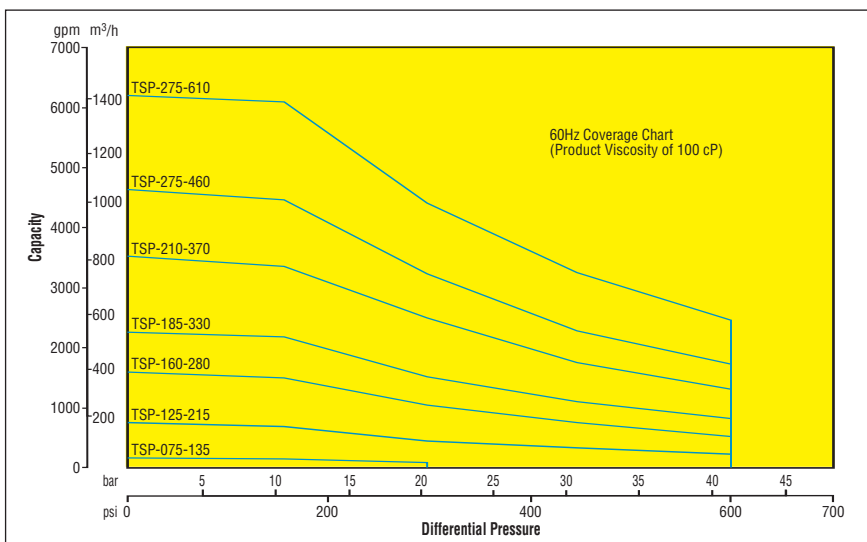

*Global Service and Technical Support*

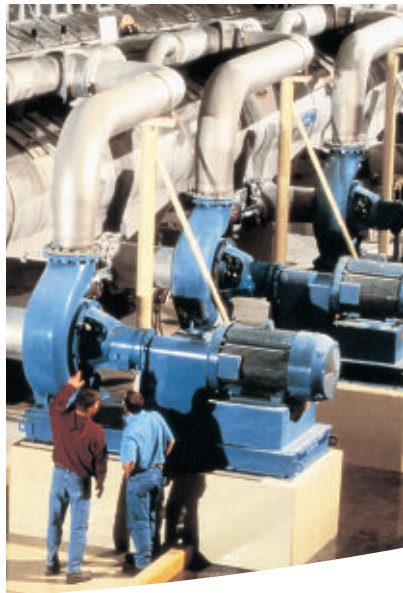

**Service Dedication**

Flowserve Engineered Services focus on providing customers with uncompromising service and support, where and when needed. Dedicated to delivering the highest quality support, Engineered Services integrate pump and materials engineering knowledge with creative service solutions.

A worldwide network of service and repair centers staffed by highly skilled engineers and technicians is available around the clock, seven days a week to respond to customer queries, to evaluate and troubleshoot problems and to provide reliable solutions.

**Strength of Experience, Commitment to Excellence**

Flowserve has long served industries requiring superior equipment performance and service life.

- Oil and gas production
- Hydrocarbon processing
- Chemical processing
- Water resources
- Power generation
- Nuclear
- Mining and mineral processing
- Pulp and paper
- General industry

Flowserve is dedicated to maximizing equipment performance and providing reliability-centered maintenance programs for pumps and related equipment, regardless of manufacturer. Using the FlowStar.net™ asset management software, Flowserve engineers and technicians track performance and support improvement programs using a service life cycle cost business approach. The results are improved reliability and increased profitability.

**Business Partner**

Flowserve partners with customers to respond to the dynamic business conditions that affect them. Flowserve will work with customers to drive efficiency, maximize throughput and control process quality. Whether user needs involve on-site technical assistance or broader project planning with full turnkey responsibility, Flowserve Engineered Services will deliver professional, reliable results.





**USA and Canada**

Flowserve Corporation  
Pump Division  
5215 North O'Connor Blvd.  
Suite 2300  
Irving, Texas 75039-5421 USA  
Telephone: 1 972 443 6500  
Telefax: 1 972 443 6800

**Europe, Middle East, Africa**

Flowserve Corporation  
Pump Division  
Via Rossini 90/92  
20033 Desio (Milan), Italy  
Telephone: 39 0362 6121  
Telefax: 39 0362 303396

**Latin America and Caribbean**

Flowserve Corporation  
Pump Division  
6840 Wynnwood Lane  
Houston, Texas 77008 USA  
Telephone: 1 713 803 4434  
Telefax: 1 713 803 4497

**Asia Pacific**

Flowserve Pte. Ltd.  
Pump Division  
200 Pandan Loop #06-03/04  
Pantech 21  
Singapore 128388  
Telephone: 65 6775 3003  
Telefax: 65 6779 4607

Bulletin PS-60-1 (E) Printed in USA. July 2005. © Flowserve Corporation

*To find your local Flowserve representative:*

For more information about Flowserve Corporation,  
visit [www.flowserve.com](http://www.flowserve.com) or call USA 1 800 728 PUMP (7867)